

## 规格书

## SPECIFICATION FOR APPROVAL

客户名称: CUSTOMER:	
日期: DATE:	2018-10-18
产品名称: PART NAME:	热释电红外传感器 Pyroelectric passive infrared sensor
产品型号: PART NO.:	PIR203S
客户型号: CUSTOMER PART NO.:	
件编号: DOCUMENT NO.:	
版本: REVISION:	A/3

客户确认APPROVED BY:
确认编号APPROVED NO.:

拟制 Prepared by	审核 Checked by	批准 Approved by

## 目 录 content

1. 特点.....	3
2. 应用.....	3
3. 使用范围.....	3
4. 传感器输出形式.....	3
5. 外形及尺寸.....	3
6. 电性能参数.....	4
7. 光学性能参数.....	5
8. 环境性能参数.....	5
9. RoHS 指令.....	5
10. 检验项目.....	5
11. 包装.....	6
12. 不合格品处理.....	6
13. 原产地.....	6
14. 协议事项.....	6

## 热释电红外传感器

### Pyroelectric passive infrared sensor

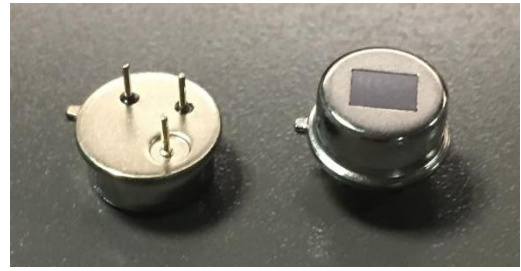

#### 1. 特点 FEATURES

\* 高灵敏度和优越的信噪比

High sensitivity and superior SNR(signal-to noise ratio)

\* 对温度变化的高稳定性

High stability for temperature change

\* 抗干扰能力强 (例如振动, 射频干扰等.)

High anti-interference ability (For example: vibration, radio frequency interference)

#### 2. 应用 APPLICATIONS

\*安防 Security

\*照明器具 Luminaire

\*家庭和其他领域 Family and other fields

#### 3. 使用范围 APPLICATIONS RANGE

本规格书使用于被动式热释电红外传感器输出装置。

This specification describes a pyroelectric passive infrared sensor for passive infrared sensor device.

#### 4. 传感器输出形式 TYPE OF SENSOR

平衡差动型 (反向串联型)

Balanced differential type (Series opposed type.)

#### 5. 外形及尺寸 APPEARANCE AND DIMENSIONS

##### 5.1 外观 VISUAL INSPECTION

表面光洁, 无划伤、污渍、生锈等现象。

There are not remarkable wounds、spots、rust and etc.

##### 5.2 外形及尺寸 APPEARANCE AND DIMENSIONS

TO-5: 具体尺寸详见图1。

TO-5 Package: see fig 1.

# PIR203S

## 6. 电性能参数 (环境温度25°C) ELECTRICAL CHARACTERISTICS( AT 25°C )

项目 ITEM	测试条件 CONDITION	规格 RATING
6.1 输出信号 Signal Output	<ul style="list-style-type: none"> <li>◆ 黑体温度:420K Black Body temperature: 420K</li> <li>◆ 调制频率 1HZ, 0.3~3.5HZ <math>\Delta f</math> Chopping Frequency: 1HZ, 0.3~ 3.5HZ <math>\Delta f</math></li> <li>◆ Vd=5V, Rs=47K<math>\Omega</math>, 放大倍数 72.5 Db Vd=5V, Rs=47K<math>\Omega</math>, the amplifier of Gain 72.5dB</li> <li>◆ 测试方法详见图2. Measurement method shown in Fig2.</li> </ul>	>3000mVp-p
6.2 噪声 Noise Output	<ul style="list-style-type: none"> <li>◆ 调制频率 1HZ, 0.3~3.5HZ <math>\Delta f</math> Chopping Frequency: 1HZ, 0.3~ 3.5HZ <math>\Delta f</math></li> <li>◆ Vd=5V, Rs=47K<math>\Omega</math>, 放大倍数 72.5 Db Vd=5V, Rs=47K<math>\Omega</math>, the amplifier of Gain 72.5dB</li> <li>◆ 测试方法详见图2. Measurement method shown in Fig2.</li> </ul>	< 70mVp-p
6.3 平衡输出 Balance output	<ul style="list-style-type: none"> <li>◆ 黑体温度:420K Black Body temperature: 420K</li> <li>◆ 调制频率 1HZ, 0.3~3.5HZ <math>\Delta f</math> Chopping Frequency: 1HZ, 0.3~ 3.5HZ <math>\Delta f</math></li> <li>◆ Vd=5V, Rs=47K<math>\Omega</math>, 放大倍数 72.5 Db Vd=5V, Rs=47K<math>\Omega</math>, the amplifier of Gain 72.5dB</li> <li>◆ 测试方法详见图2和图3. Measurement method shown in Fig2 and Fig3.</li> </ul> <p style="text-align: center;">VA = A单元的灵敏度 (Vp-p) VA = A Element sensitivity (Vp-p) VB = B单元的灵敏度 (Vp-p) VB = B Element sensitivity (Vp-p)</p>	$\frac{ VA-VB }{(VA+VB)} \times 100\% \leq 10\%$
6.4 电源电压 Operating Voltage	单电源供电 Single power supply RS=47K $\Omega$	2~15V
6.5 源极电压 Source Voltage	VD=5V, RS=47K $\Omega$	0.4~1.0V
6.6 基本测试电路 Circuit Configuration	详见图 See Fig.3	
6.7 响应时间 Warm-up Time	传感器通电后, 输出信号稳定的时间 After it conneted, it with the measurement amplifier for Fig.3 description that turns on the power supply beforehand, the amplification output is time until stabilizing.	Max: 25 Sec

## 7. 光学性能参数 OPTICAL CHARACTERISTICS

项目 ITEM	规格 RATING
7.1 入射视角图 Field of View	X轴方向: 138度. 113 degrees from center of Element on Axis X. Y轴方向: 125度. 90 degrees from center of Element on Axis Y. 详见图5 See Fig 5
7.2 接收波长 Response wavelength band	基板材料: 硅 Filter substrate: Silicon 截止波长: $5.5 \pm 0.5 \mu m$ Cut on wavelength: $5.5 \pm 0.5 \mu m$ 平均透过率: $7 \sim 14 \mu m \geq 75\%$ Transmission: $7 \sim 14 \mu m \geq 75\%$
7.3 滤光片透过特性曲线 Transmission Characteristics of filter	详见图6 See Fig 6

## 8. 环境性能参数 ENVIRONMENTAL REQUIREMENTS

项目 ITEM	规格 RATING
8.1 使用温度范围 Operating Temperature	$-30 \sim 70 \text{ } ^\circ\text{C}$
8.2 保存温度范围 Storage Temperature	$-40 \sim 80 \text{ } ^\circ\text{C}$
8.3 耐湿度性 Relative Humidity	噪声在 $30^\circ\text{C}$ , 相对湿度为90~95%条件下和常温常湿条件下没有增大。 The sensor shall operate without increase in Noise Output when exposed to 90 to 95% RH at $30^\circ\text{C}$ continuously
8.4 气密性 Hermetic Seal	$125 \pm 5^\circ\text{C}$ 氟碳浴 (FC-40) 中浸泡20秒, 不产生气泡。 No bubbles visible in the $125 \pm 5^\circ\text{C}$ fluorocarbon bath(FC-40) for 20sec
8.5 可靠性试验 Reliability Test	参考附件1 (13~14页) Specified in 《Appendix》1 ( page13~14)

## 9. ROHS 指令 ROHS COMPLIANCE

本产品符合欧盟RoHS指令要求.

This product conforms to RoHS regulatin.

## 10. 检验项目 INSPECTION

### 10.1 制程检验 Process inspection

全检: 项目 6 电性能参数, 包括 6.1~6.3,6.5 项。

100% inspection: Item 6.1 to 6.3 and 6.5 among the electric performances of item 6.

## 10.2 发货检验 OUTGOING INSPECTION

发货前按照发货抽检标准对项目 6 的 6.1~6.3,6.5 项和项目 5 的 5.1,5.3 项进行抽检。

Based on statistical sampling inspection method every manufacture lot is inspected for the electrical characteristics item 6.1to 6.3 ,6.5 of the Item 6,and item 5.1 and 5.3 of the appearance of item 5.

## 11. 包装 PACKING

货物包装牢固，无破损现象。

The packaging is solid and there isn't breakage

## 12. 不合格品处理 PROCESS ATFAILURE

在收货过程检验中，发现不合格产品，双方对此进行协商处理。

In case of finding of failure incoming or process inspection after receipt of products, Both sides negotiate to deal with the failure

## 13. 原产地 PRODUCTION GROUND

中国

China

## 14. 协议事项 REVISION

本协议内容的变更必须经过双方协商，并出具文字文件确认。

Any revision of this specification should be made in writing by discussion.

俯视图  
(图 A)

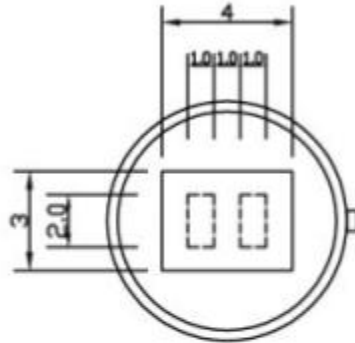

侧视图  
(图 B)

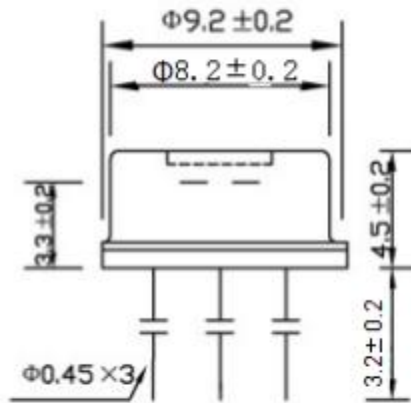

底视图  
(图 C)

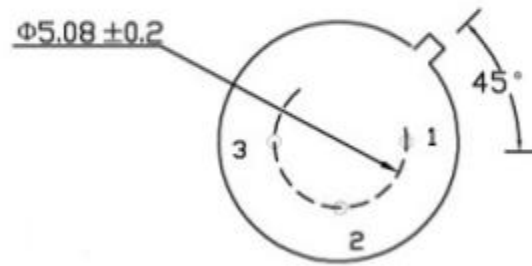

管脚定义：

1-VDD

2-REL

3-VSS

图 1 尺寸规格图

FIG.1 Dimensions chart

热释电红外传感器测试方法

## Pyroelectric Passive Infrared sensor measurement method

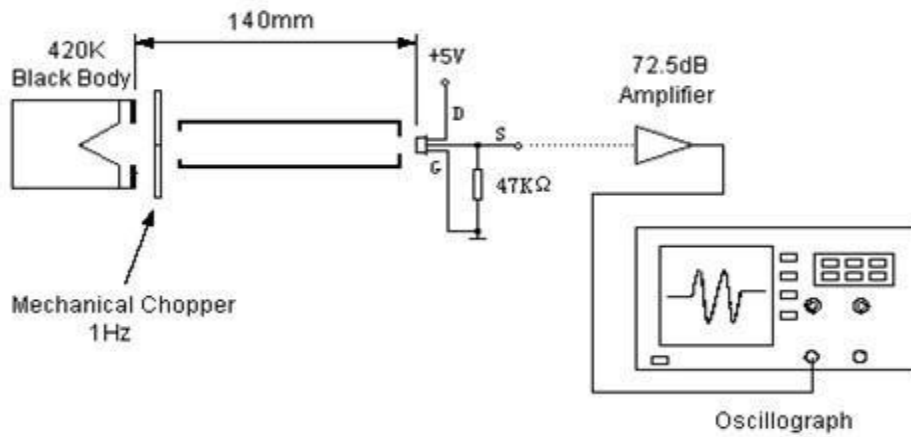

### 测量条件 TEST CONDITION

- ◆ 环境温度: 25°C
- ◆ Environmental temperature: 25°C
- ◆ 黑体温度: 420K
- ◆ Black Body temperature: 420K
- ◆ 调制频率 1 赫兹, 0.3~3.5 赫兹  $\Delta f$
- ◆ Chopping Frequency: 1HZ, 0.3~ 3.5HZ  $\Delta f$
- ◆ 放大倍数 72.5 dB
- ◆ the amplifier of Gain 72.5dB

图 2 热释电传感器测试方法

FIG.2 PYROELECTRIC PASSIVE INFRARED SENSOR MEASUREMENT METHOD



## 平衡度测试方法

### BALANCE MEASUREMENT METHOD



图 3 平衡度测试方法

FIG.3 BALANCE MEASUREMENT METHOD

热释电传感器的灵敏平衡度是通过测量每个单元的灵敏度，并采用下列公式计算得出。

Pyroelectric Passive Infrared sensor sensitivity balance is measured by testing the single unit sensitivity, and using the following equation.

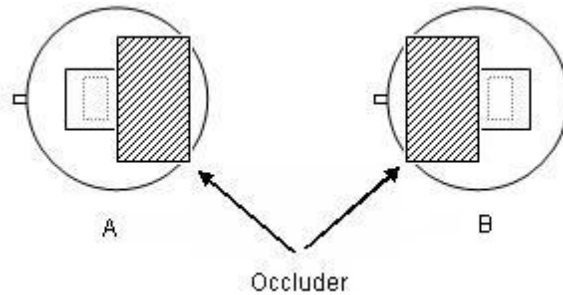
$$\text{Balance} = |V_A - V_B| / (V_A + V_B) \times 100\%$$

$V_A$  = A单元的灵敏度 (Vp-p)

$V_A$  = A Element sensitivity (Vp-p)

$V_B$  = B单元的灵敏度 (Vp-p)

$V_B$  = B Element sensitivity (Vp-p)

## 测试电路图

### TEST CIRCUIT CONFIGURATION

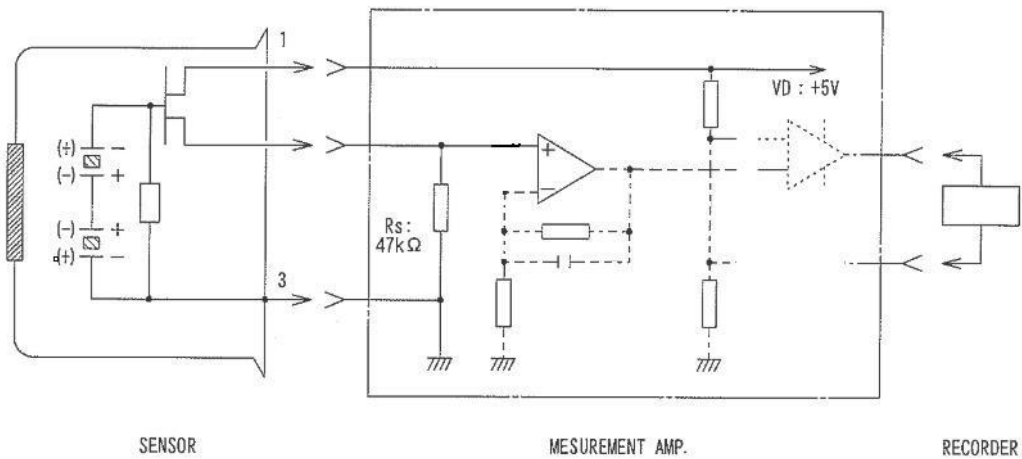

- 1. 漏极 (Drain)
- 2. 源极 (Source)
- 3. 地 (Ground)

图 4 测试电路图

FIG.4 TEST CIRCUIT CONFIGURATION

入射视角图  
FIELD OF VIEW



图5 入射视角  
FIG.5 FIEL OF VIEW

滤光窗口特性  
TYPICAL TRANSMISSION CHARACTERISTICS OF FILTER



图6 滤光窗口特性  
FIG.6 TYPICAL TRANSMISSION CHARACTERISTICS OF FILTER

# PIR203S

《附件》1 可靠性试验项目

## 《Appendix》1 RELIABILITY TEST ITEM

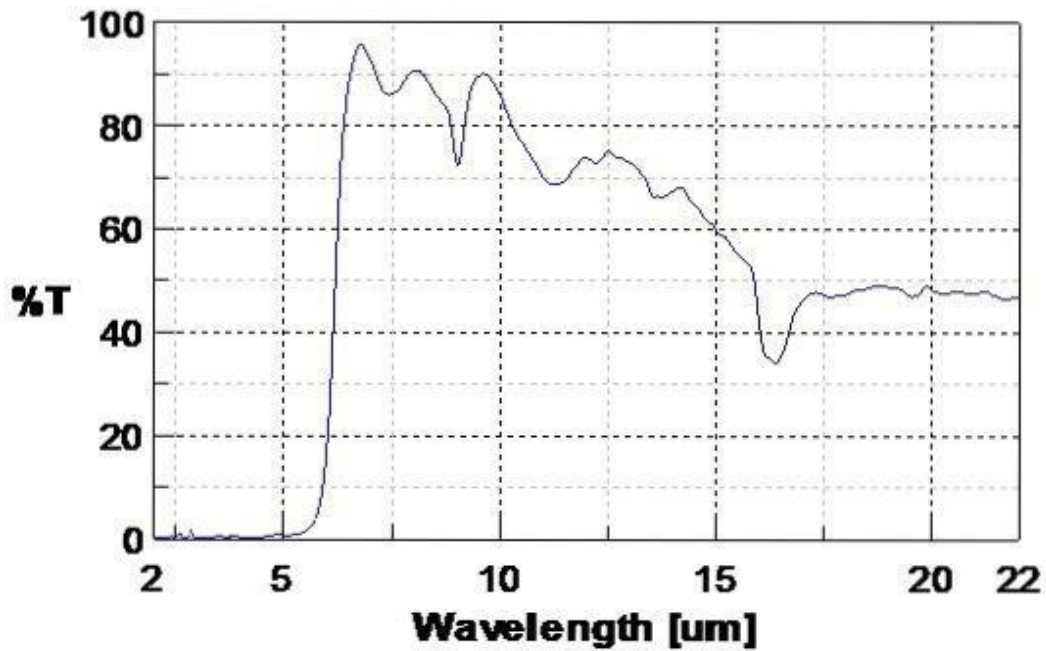
以下测试项目存在疑问或元件被更改，测试结果需要协商讨论。

when a doubt arises in the following test items, or when components have been changed, these tests are performed again after consultation by discussion.

项目 ITEM	测试条件 TEST CONDITION	试验结果 RESULT
高温保存 High Temperature storage	温度 Temperature: 85℃ 时间 Time : 500 Hr	测试完成后，放在室温条件 3 小时后再进行测量 After testing finished, retest the sensor with naturally nomalized at room temperature for 3Hr  1. 外观：无明显损伤 visual inspection: NO remarkable damage  2. 灵敏度: 初始测定值 20 % 内 Sensitivity: ±20% of initial value  3. 噪声: 初始测定值+100mV Noise: +100mV of initial value
低温保存 Low Temperature storage	温度 Temperature: -30℃ 时间 Time : 500 Hr	
高温高湿保存 High Temperature & Humidity storage	温度 Temperature: 60℃ 相对湿度 humidity: 90% 时间 Time : 500 Hr	
高温高湿通电试验(THB) Thermal humidity bias	温度 Temperature: 60℃ 相对湿度 humidity: 90% 时间 Time : 48 Hr 供电电压 Voltage : 5.0VDC	
热循环 Heat shock	-40℃, 30 分钟-->25℃, 30 分钟 -->85℃, 30 分钟, 共 10 个循环 -40℃, 30min-->25℃, 30min-->80℃, 30min*10cycles	
振动 Vibration	频率 Frequency : 10~55HZ 全振幅 Total amplitude : 1.5mm 加 振时间 Vibration time: 各 X,Y,Z 方向 60min 60min each of Z,Y,Z axis	
耐静电试验 ESD	条件 Condition: C=200pf, R=0 ohm V=200V	
跌落试验 Natural drop	高度 Height : 750mm 跌落次数 Drop times : 3 次 3times	
端子引线强度 Terminal pull Strength	拉力 Pull strength : 19.5N 保持时间 Hold time : 5sec	
可焊性 Soldering	焊接温度 temperature of solder: 245℃ 焊锡种类 solder kind : Sn-Cu 浸渍时间 soaking time: 3sec	
焊锡耐热性 Solder Heatproof	焊接温度 temperature of solder tank : 260±5℃ 浸渍时间 soaking time: 10±1 秒, 浸润到离引脚根部 3mm 处 10 ± 1sec Dipping leads submerge into	

# PIR203S

	solder down to 3mm below stem	
锡须试验 Tin Whisker Test	温度 Temperature: 60℃ 相对湿度 humidity: 93% 时间Time : 1000 Hr	
气密性 Hermetic Seal	在125±5℃的氟碳浴（FC-40）中浸泡20秒 Soaking in the 125 ± 5 °C fluorocarbon bath(FC-40) for 20sec	不产生气泡 No bubble visible